

5A, Standalone Li-ion Battery Charger CN3704

General Descriptions:

The CN3704 is a PWM switch-mode lithium ion battery charger controller for 4 cell li-ion battery in a small package using few external components.

The CN3704 is specially designed for charging lithium ion batteries with constant current and constant voltage mode. In constant voltage mode, the regulation voltage is fixed at 16.8V with $\pm 1\%$ accuracy. The constant charging current is programmable with a single sense resistor.

Deeply discharged batteries are automatically trickle charged at 15% of the programmed constant charging current until the cell voltage exceeds 11.2V. The charge cycle is terminated once the charging current drops to a level set by an on-chip resistor and an external resistor, and a new charge cycle automatically restarts if the battery voltage falls below 16V. CN3704 will automatically enter sleep mode when input voltage is lower than battery voltage.

Other features include undervoltage lockout, battery temperature monitoring and status indication, etc.

CN3704 is available in a space-saving 16-pin TSSOP package.

Applications:

- Notebook Computers
- Model Plane
- Battery-Backup Systems
- Portable Industrial and Medical Equipment
- Standalone Battery Chargers

Features:

- Wide Input Voltage: 7.5V to 28V
- Complete Charger Controller for 4 cell Lithium-ion Battery
- Charge Current Up to 5A
- High PWM Switching Frequency: 300KHz
- Constant Charging Voltage Accuracy: $\pm 1\%$
- Charging Current is programmed with a sense resistor
- Automatic Conditioning of Deeply Discharged Batteries
- End-of-Charge Current can be set by an external resistor
- Battery Temperature Monitoring
- Automatic Recharge
- Charger Status Indication
- Soft Start
- Battery Overvoltage Protection
- Operating Ambient Temperature -40°C to $+85^{\circ}\text{C}$
- Available in 16 Pin TSSOP Package
- Pb-free , RoHS Compliant, and Halogen Free

Pin Assignment:

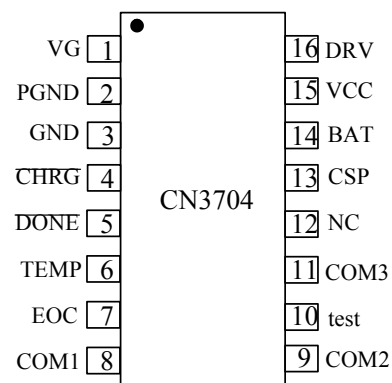

CONSONANCE

Typical Application Circuit:

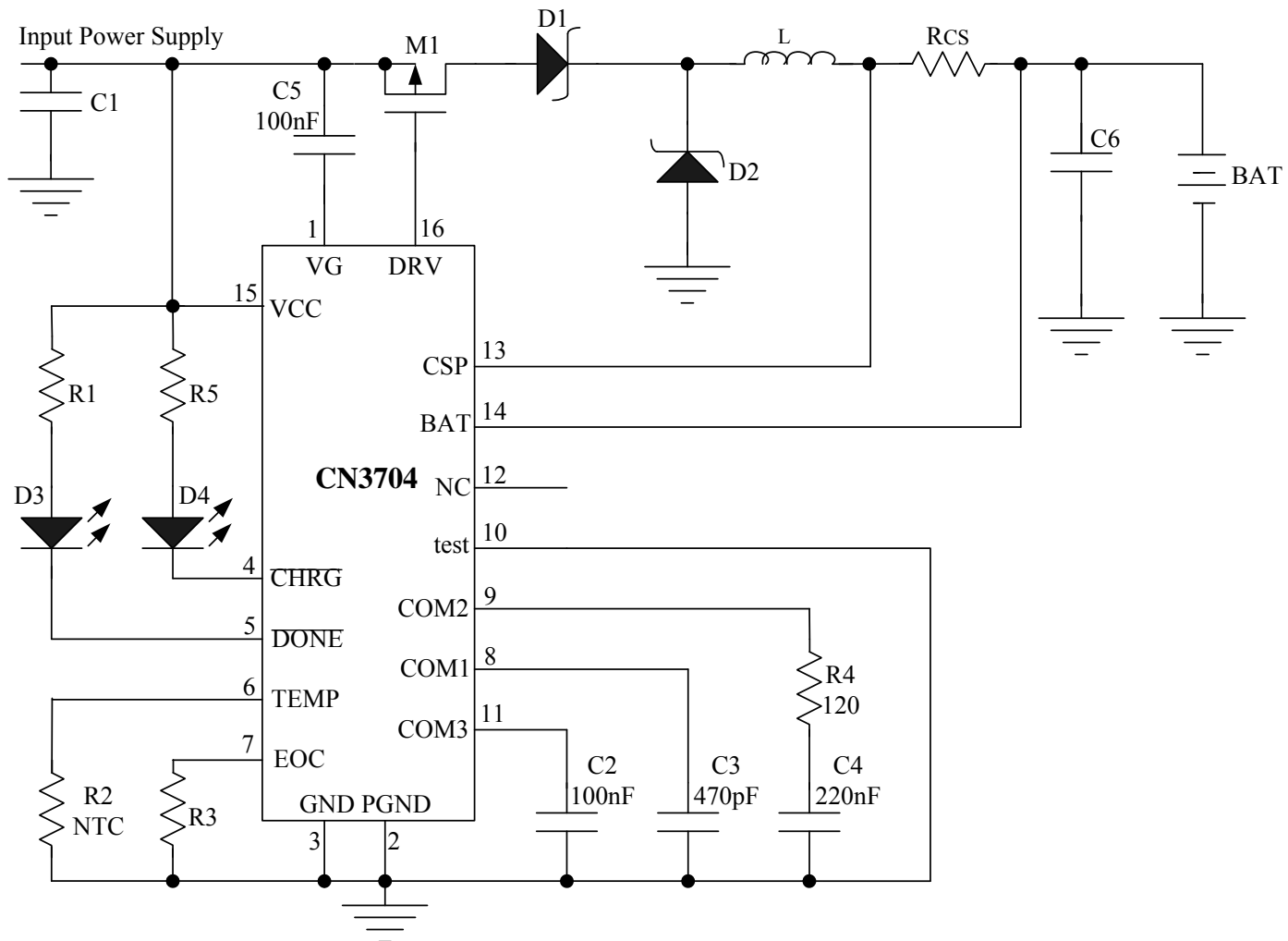

Figure 1 Typical Application Circuit

Ordering Information:

Part No.	Operating Ambient Temperature	Constant Charging Voltage
CN3704	-40°C to +85°C	16.8V(4 Li-ion Batteries)

CONSONANCE

Pin Description:

Pin No.	Name	Descriptions
1	VG	Internal Voltage Regulator. VG internally supplies power to gate driver, connect a 100nF capacitor between VG pin and VCC pin.
2	PGND	Power Ground.
3	GND	Analog Ground.
4	$\overline{\text{CHRG}}$	Open-Drain Output. When the battery is being charged, this pin is pulled low by an internal switch. Otherwise this pin is in high impedance state.
5	$\overline{\text{DONE}}$	Open-Drain Output. When the charging is terminated, this pin is pulled low by an internal switch. Otherwise this pin is in high impedance state.
6	TEMP	Battery Temperature Monitoring Input. Connect an NTC resistor from this pin to GND.
7	EOC	End-of-Charge Current Setting Pin. Connect this pin to GND directly or via a resistor.
8	COM1	Loop Compensation Input 1. Connect a 470pF capacitor from this pin to GND.
9	COM2	Loop Compensation Input 2. Connect a 220nF capacitor in series with an 120Ω resistor from this pin to GND.
10	test	Test pin. Connected this pin to GND.
11	COM3	Loop Compensation Input 3. Connect an 100nF capacitor from this pin to GND.
12	NC	No Connection
13	CSP	Positive Input for Charging Current Sensing. This pin and the BAT pin measure the voltage drop across the sense resistor RCS, to provide the current signals required.
14	BAT	Battery Voltage Sensing Input and the Negative Input for Charging Current Sensing. A precision resistor divider sets the regulation voltage on this pin in constant voltage mode.
15	VCC	External DC Power Supply Input. VCC is also the power supply for internal circuit. Bypass this pin with a capacitor.
16	DRV	Drive the gate of external P-channel MOSFET.

Absolute Maximum Ratings

Voltage from VCC, CHRG, DONE to GND.....	−0.3V to 30V
Voltage from VG, DRV to GND.....	8V
Voltage from CSP, BAT to GND.....	−0.3V to 28V
Voltage from COM3 to GND.....	6.5V
Voltage from Other Pins to GND.....	−0.3V to $V_{\text{COM3}}+0.3\text{V}$
Storage Temperature.....	−65°C---150°C
Operating Ambient Temperature.....	−40°C---85°C
Lead Temperature(Soldering, 10 seconds).....	260°C

Stresses beyond those listed under 'Absolute Maximum Ratings' may cause permanent damage to the device. These are stress ratings only and functional operation of the device at these or any other conditions above those indicated in the operational sections of the specifications is not implied. Exposure to Absolute Maximum Rating Conditions for extended periods may affect device reliability.

CONSONANCE

Electrical Characteristics:

(VCC=20V, T_A=-40°C to 85°C, unless otherwise noted)

Parameters	Symbol	Conditions	Min	Typ	Max	Unit	
Input Voltage Range	VCC		7.5		28	V	
Undervoltage lockout Threshold	UVLO		4.2	6	7.3	V	
Operating Current	I _{VCC}	No switching	1.4	1.95	2.5	mA	
Regulation Voltage	V _{REG}	Constant voltage mode	16.632	16.8	16.968	V	
Current Sense	V _{CS}	V _{BAT} > 11.2V, V _{CSP} - V _{BAT}	190	200	210	mV	
		V _{BAT} < 11.2V, V _{CSP} - V _{BAT}	15	27	42		
Current into BAT Pin	I _{BAT}	Termination or Sleep Mode		15	25	uA	
Precharge Threshold	V _{PRE}	V _{BAT} rising	10.8	11.2	11.6	V	
Precharge Threshold Hysteresis	H _{PRE}	V _{BAT} falling		0.4		V	
Recharge Threshold	V _{RE}	V _{BAT} falling		16		V	
Overvoltage Trip Level	V _{OV}	V _{BAT} rising	1.06	1.08	1.1	V _{REG}	
Overvoltage Clear Level	V _{clr}	V _{BAT} falling	0.98	1	1.02		
TEMP Pin							
Pull up Current	I _{up}		42	55	68	uA	
High Threshold	V _{thh}	TEMP Voltage Rising	1.57	1.61	1.65	V	
Low Threshold	V _{thl}	TEMP Voltage Falling	0.145	0.175	0.205	V	
CHRG Pin							
CHRG Pin Sink Current	I _{CHRG}	V _{CHRG} =1V, charge mode	7	12	18	mA	
CHRG Leakage Current	I _{LK1}	V _{CHRG} =25V, termination mode			1	uA	
DONE Pin							
DONE Sink Current	I _{DONE}	V _{DONE} =1V, termination mode	7	12	18	mA	
DONE Leakage Current	I _{LK2}	V _{DONE} =25V, charge mode			1	uA	
Oscillator							
Switching Frequency	f _{osc}		240	300	360	kHz	
Maximum Duty Cycle	D _{max}			94		%	
Sleep Mode							
Sleep Mode Threshold (measure VCC - V _{BAT})	V _{SLP}	VCC falling	V _{BAT} =8V	0.06	0.1	0.14	V
			V _{BAT} =12V	0.1	0.14	0.18	
			V _{BAT} =18V	0.18	0.23	0.28	
Sleep mode Release Threshold (measure VCC - V _{BAT})	V _{SLPR}	VCC rising,	V _{BAT} =8V	0.26	0.32	0.39	V
			V _{BAT} =12V	0.32	0.42	0.52	
			V _{BAT} =18V	0.38	0.47	0.58	
DRV Pin							
V _{DRV} High (VCC - V _{DRV})	V _H	I _{DRV} = -10mA		60		mV	
V _{DRV} Low (VCC - V _{DRV})	V _L	I _{DRV} = 0mA	5	6.5	8	V	
Rise Time	t _r	Load = 2nF, 10% to 90%	30	40	65	ns	
Fall Time	t _f	Load = 2nF, 90% to 10%	30	40	65	ns	

CONSONANCE

Detailed Description:

The CN3704 is a constant current, constant voltage Li-Ion battery charger controller that adopts PWM step-down (buck) switching architecture. The charge current is set by an external sense resistor (R_{CS}) across the CSP and BAT pins. The final battery regulation voltage in constant voltage mode is internally set to 16.8V with 1% accuracy.

A charge cycle begins when the voltage at the VCC pin rises above the UVLO level and is greater than the battery voltage by V_{SLPR} . At the beginning of the charge cycle, if the battery voltage is less than 11.2V, the charger goes into trickle charge mode. The trickle charge current is internally set to 15%(Typical) of the full-scale current. When the battery voltage exceeds 11.2V, the charger goes into the full-scale constant current charge mode. In constant current mode, the charge current is set by the external sense resistor R_{CS} and an internal 200mV reference, so the charge current equals to $200\text{mV}/R_{CS}$. When the battery voltage approaches the regulation voltage, the charger goes into constant voltage mode, and the charge current will start to decrease. When the charge current drops to a level that is set by the resistor at EOC pin, the charge cycle is terminated, the DRV pin is pulled up to VCC, and an internal comparator turns off the internal pull-down N-channel MOSFET at the $\overline{\text{CHRG}}$ pin to indicate that the charge cycle is terminated. During the charge cycle termination status, another internal pull-down N-channel MOSFET at the $\overline{\text{DONE}}$ pin is turned on to indicate the termination status.

To restart the charge cycle, just remove and reapply the input voltage. Also, a new charge cycle will begin if the battery voltage drops below the recharge threshold voltage of 16V.

When the input voltage is not present, the charger goes into sleep mode.

A 10k Ω NTC (negative temperature coefficient) thermistor can be connected from the TEMP pin to ground for battery temperature qualification. The charge cycle is suspended if the battery's temperature is outside of the acceptable range.

An overvoltage comparator guards against voltage transient overshoots (>8% of regulation voltage). In this case, P-channel MOSFET are turned off until the overvoltage condition is cleared. This feature is useful for battery load dump or sudden removal of battery.

The charging profile is shown in Figure 2.

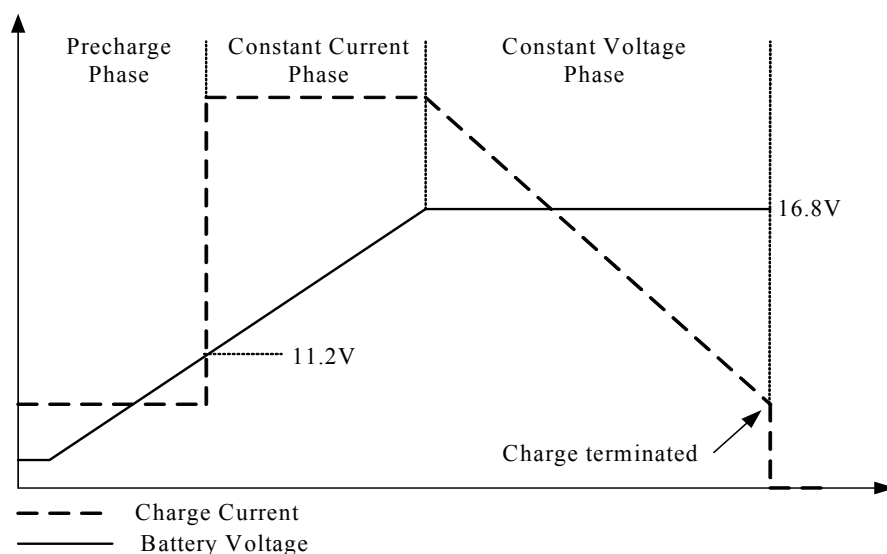

Figure 2 The Charging Profile

CONSONANCE

Application Information

Undervoltage Lockout (UVLO)

An undervoltage lockout circuit monitors the input voltage and keeps the charger off if VCC falls below 6V(Typical).

Trickle Charge Mode

At the beginning of a charge cycle, if the battery voltage is below 11.2V, the charger goes into trickle charge mode with the charge current reduced to 15% of the full-scale current.

Charge Current Setting

The full-scale charge current, namely the charge current in constant current mode, is decided by the following formula:

$$I_{CH} = \frac{200\text{mV}}{R_{CS}}$$

Where:

I_{CH} is the full scale charge current

R_{CS} is the resistor between the CSP pin and BAT pin

End-of-Charge Current Setting

End-of-charge current can be set by connecting a resistor from EOC pin to GND, and is decided by the following equation:

$$I_{EOC} = \frac{1.278 \times (14350 + R_{ext})}{R_{CS} \times 10^6}$$

Where:

- I_{EOC} is the end-of-charge current in Ampere
- R_{ext} is the external resistance from EOC pin to GND in Ω . R_{ext} can not be great than 100K Ω , otherwise the charging may not be terminated correctly.
- R_{CS} is the current sense resistance between CSP pin and BAT pin in Ω

It is our interest to calculate the ratio between I_{EOC} and I_{CH} :

$$\frac{I_{EOC}}{I_{CH}} = \frac{\frac{1.278 \times (14350 + R_{ext})}{R_{CS} \times 10^6}}{\frac{0.2}{R_{CS}}} = \frac{1.278 \times (14350 + R_{ext})}{0.2 \times 10^6}$$

When $R_{ext}=0\Omega$, the minimum $I_{EOC}/I_{CH}=9.17\%$

When $R_{ext}=100\text{K}\Omega$, the maximum $I_{EOC}/I_{CH}=73\%$

Automatic Battery Recharge

After the charge cycle is completed and both the battery and the input power supply (wall adapter) are still Connected, a new charge cycle will begin if the battery voltage drops below 16V due to self-discharge or external loading. This will keep the battery capacity at more than 80% at all times without manually restarting the charge cycle.

Battery Temperature Monitoring

A negative temperature coefficient (NTC) thermistor located close to the battery pack can be used to monitor battery temperature and will not allow charging unless the battery temperature is within an acceptable range. Connect a 10k Ω thermistor from the TEMP pin to ground. Internally, for hot temperature, the low voltage

CONSONANCE

threshold is set at 175mV which is equal to 50°C (RNTC \approx 3.5k Ω). For cold temperature, the high voltage threshold is set at 1.61V which is equal to 0°C (RNTC \approx 32k Ω) with 50uA of pull-up current.

Once the temperature is outside the window, the charge cycle will be suspended, and the charge cycle resumes if the temperature is back to the acceptable range.

The TEMP pin's pull up current is about 50uA, so the NTC thermistor's resistance should be 10k Ω at 25°C, about 3.5k Ω at hot temperature threshold, and about 32k Ω at cold temperature threshold. The NTC thermistor such as TH11-3H103F, MF52(10 k Ω), QWX-103 and NCP18XH103F03RB can work well with CN3704. The above mentioned part numbers are for reference only, the users can select the right NTC thermistor part number based on their requirements.

If battery temperature monitoring function is not needed, just connect a 10K Ω resistor from TEMP pin to GND.

Status Indication

The CN3704 has 2 open-drain status outputs: $\overline{\text{CHRG}}$ and $\overline{\text{DONE}}$. $\overline{\text{CHRG}}$ is pulled low when the charger is in charging status, otherwise $\overline{\text{CHRG}}$ becomes high impedance. $\overline{\text{DONE}}$ is pulled low if the charger is in charge termination status, otherwise $\overline{\text{DONE}}$ becomes high impedance.

When the battery is not present, the charger charges the output capacitor to the regulation voltage quickly, then the BAT pin's voltage decays slowly to recharge threshold because of low leakage current at BAT pin, which results in a ripple waveform at BAT pin, in the meantime, $\overline{\text{CHRG}}$ pin outputs a pulse to indicate that the battery's absence. The pulse's frequency is around 10Hz when a 10uF output capacitor is used.

The open drain status output that is not used should be tied to ground.

The table 1 lists the two indicator status and its corresponding charging status. It is supposed that red LED is connected to $\overline{\text{CHRG}}$ pin and green LED is connected to $\overline{\text{DONE}}$ pin.

$\overline{\text{CHRG}}$ pin	$\overline{\text{DONE}}$ pin	State Description
Low(the red LED on)	High Impedance(the green LED off)	Charging
High Impedance(the red LED off)	Low(the green LED on)	Charge termination
Pulse signal	Pulse signal	Battery not connected
High Impedance(the red LED off)	High Impedance(the green LED off)	There are three possible state: <ul style="list-style-type: none"> ● the voltage at the VCC pin below the UVLO level or ● the voltage at the VCC pin below V_{BAT} or ● abnormal battery's temp

Table 1 Indication Status

Gate Drive

The CN3704's gate driver can provide high transient currents to drive the external pass transistor. The rise and fall times are typically 40ns when driving a 2000pF load, which is typical for a P-channel MOSFET with Rds(on) in the range of 50m Ω .

A voltage clamp is added to limit the gate drive to 8V max. below VCC. For example, if VCC is 20V, then the DRV pin output will be pulled down to 12V min. This allows low voltage P-channel MOSFETs with superior Rds(on) to be used as the pass transistor thus increasing efficiency.

Loop Compensation

In order to make sure that the current loop and the voltage loop are stable, the following compensation components are necessary:

- (1) A 470pF capacitor from the COM1 pin to GND
- (2) A series 220nF ceramic capacitor and 120 Ω resistor from the COM2 pin to GND

CONSONANCE

(3) An 100nF ceramic capacitor from the COM3 pin to GND

Battery Detection

CN3704 does not provide battery detection function, when the battery is not present, the charger charges the output capacitor to the regulation voltage quickly, then the BAT pin's voltage decays slowly to recharge threshold because of low leakage current at BAT pin, which results in a ripple waveform at BAT pin, in the meantime, $\overline{\text{CHRG}}$ pin outputs a pulse to indicate that the battery's absence. The pulse's frequency is around 10Hz when a 10uF output capacitor is used.

It is generally not a good practice to connect a battery while the charger is running. The charger may provide a large surge current into the battery for a brief time.

Input and Output Capacitors

Since the input capacitor is assumed to absorb all input switching ripple current in the converter, it must have an adequate ripple current rating. Worst-case RMS ripple current is approximately one-half of output charge current.

The selection of output capacitor is primarily determined by the ESR required to minimize ripple voltage and load step transients. Generally speaking, a 10uF ceramic capacitor can be used.

Inductor Selection

During P-channel MOSFET's on time, the inductor current increases, and decreases during P-channel MOSFET's off time, the inductor's ripple current increases with lower inductance and higher input voltage. Higher inductor ripple current results in higher charge current ripple and greater core losses. So the inductor's ripple current should be limited within a reasonable range.

The inductor's ripple current is given by the following formula:

$$\Delta I_L = \frac{1}{f(L)} V_{\text{BAT}} \left(1 - \frac{V_{\text{BAT}}}{V_{\text{CC}}}\right)$$

Where,

f is the switching frequency 300KHz

L is the inductor value

V_{BAT} is the battery voltage

VCC is the input voltage

A reasonable starting point for setting inductor ripple current is $\Delta I_L = 0.4 \times I_{\text{CH}}$, I_{CH} is the charge current. Remember that the maximum ΔI_L occurs at the maximum input voltage and the lowest inductor value. So lower charge current generally calls for larger inductor value.

Use Table 2 as a guide for selecting the correct inductor value for your application.

Charge Current	Input Voltage	Inductor Value
1A	>20V	40uH
	<20V	30uH
2A	>20V	30uH
	<20V	20uH
3A	>20V	20uH
	<20V	15uH
4A	>20V	15uH
	<20V	10uH
5A	>20V	10uH
	<20V	8uH

Table 2 Guide to Select Inductor Value

CONSONANCE

MOSFET Selection

The CN3704 uses a P-channel power MOSFET switch. The MOSFET must be selected to meet the efficiency or power dissipation requirements of the charging circuit as well as the maximum temperature of the MOSFET. The peak-to-peak gate drive voltage is set internally, this voltage is typically 6.5V. Consequently, logic-level threshold MOSFETs must be used. Pay close attention to the BV_{DSS} specification for the MOSFET as well; many of the logic level MOSFETs are limited to 30V or less.

Selection criteria for the power MOSFET includes the “on” resistance $R_{ds(on)}$, total gate charge Q_g , reverse transfer capacitance C_{RSS} , input voltage and maximum charge current.

The MOSFET power dissipation at maximum output current is approximated by the equation:

$$P_d = \frac{V_{BAT}}{V_{CC}} \times R_{ds(on)} \times I_{CH}^2 \times (1+0.005dT)$$

Where:

P_d is the power dissipation of the power MOSFET

V_{BAT} is the maximum battery voltage

V_{CC} is the minimum input voltage

$R_{ds(on)}$ is the power MOSFET’s on resistance at room temperature

I_{CH} is the charge current

dT is the temperature difference between actual ambient temperature and room temperature(25°C)

In addition to the $I^2R_{ds(on)}$ loss, the power MOSFET still has transition loss, which are highest at the highest input voltage. Generally speaking, for $V_{IN} < 20V$, the $I^2R_{ds(on)}$ loss may be dominant, so the MOSFET with lower $R_{ds(on)}$ should be selected for better efficiency; for $V_{IN} > 20V$, the transition loss may be dominant, so the MOSFET with lower C_{RSS} can provide better efficiency. C_{RSS} is usually specified in the MOSFET characteristics; if not, then C_{RSS} can be calculated using $C_{RSS} = Q_{GD}/\Delta V_{DS}$.

The MOSFETs such as AO4459, STM9435(or WT9435), AO3407A can be used. The part numbers listed above are for reference only, the users can select the right MOSFET based on their requirements.

Diode Selection

The diodes D1 and D2 in Figure 1 are schottky diode, the current rating of the diodes should be at least the charge current limit, the voltage rating of the diode should exceed the maximum expected input voltage.

The diode that is much larger than that is sufficient can result in larger transition losses due to their larger junction capacitance.

Disable Charging with TEMP Pin

The charging can be disabled with TEMP pin, as shown in Figure 3:

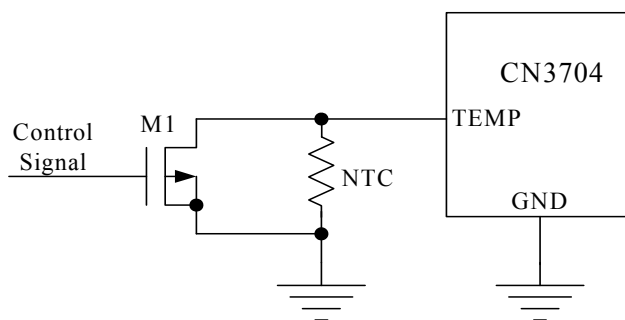

Note: M1 is N-Channel MOSFET

Figure 3 Disable Charging With TEMP Pin

CONSONANCE

When control signal is high, N-channel MOSFET M1 is turned on, the voltage at TEMP pin is pulled down to GND, which will disable the charging;

When control signal is low, N-channel MOSFET is turned off, the voltage at TEMP pin is determined by NTC thermistor, which performs normal battery temperature monitoring function.

About Battery Current In Sleep Mode

In the typical application circuit shown in Figure 1, when input voltage is powered off or lower than battery voltage, CN3704 will enter sleep mode. In sleep mode, the battery current includes:

- (1) The current into BAT pin and CSP pin, which is about $14\mu\text{A}$ ($V_{\text{BAT}} = 16.8\text{V}$).
- (2) The current from battery to VCC pin via diode D1, which is determined by D1's leakage current.

The current will charge capacitance C1 at VCC pin, which will make VCC voltage a bit higher. To avoid erratic operation, a resistor in parallel with capacitance C1 may be needed to discharge the capacitance, the resistor value is determined by diode D1's leakage, generally speaking, a $20\text{K}\Omega$ resistor can achieve the task.

The current from battery to GND via diode D2, which is also determined by D2's leakage current.

PCB Layout Considerations

When laying out the printed circuit board, the following considerations should be taken to ensure proper operation of the IC.

- (1) To minimize radiation, the 2 diodes, pass transistor, inductor and the input bypass capacitor traces should be kept as short as possible. The positive side of the input capacitor should be close to the source of the P-channel MOSFET; it provides the AC current to the pass transistor. The connection between the catch diode and the pass transistor should also be kept as short as possible.
- (2) The compensation capacitor connected at the COM1, COM2 and COM3 pins should return to the analog ground pin of the IC. This will prevent ground noise from disrupting the loop stability.
- (3) Output capacitor ground connections need to feed into same copper that connects to the input capacitor ground before tying back into system ground.
- (4) Analog ground and power ground (or switching ground) should return to system ground separately.
- (5) The ground pins also work as a heat sink, therefore use a generous amount of copper around the ground pins. This is especially important for high VCC and/or high gate capacitance applications.
- (6) Place the charge current sense resistor R_{CS} right next to the inductor output but oriented such that the IC's CSP and BAT traces going to R_{CS} are not long. The 2 traces need to be routed together as a single pair on the same layer at any given time with smallest trace spacing possible.
- (7) The CSP and BAT pins should be connected directly to the current sense resistor (Kelvin sensing) for best charge current accuracy. See Figure 4 as an example.

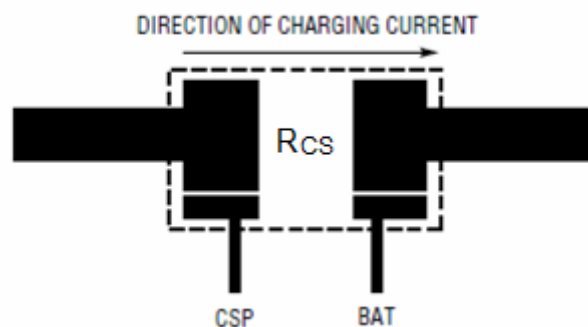
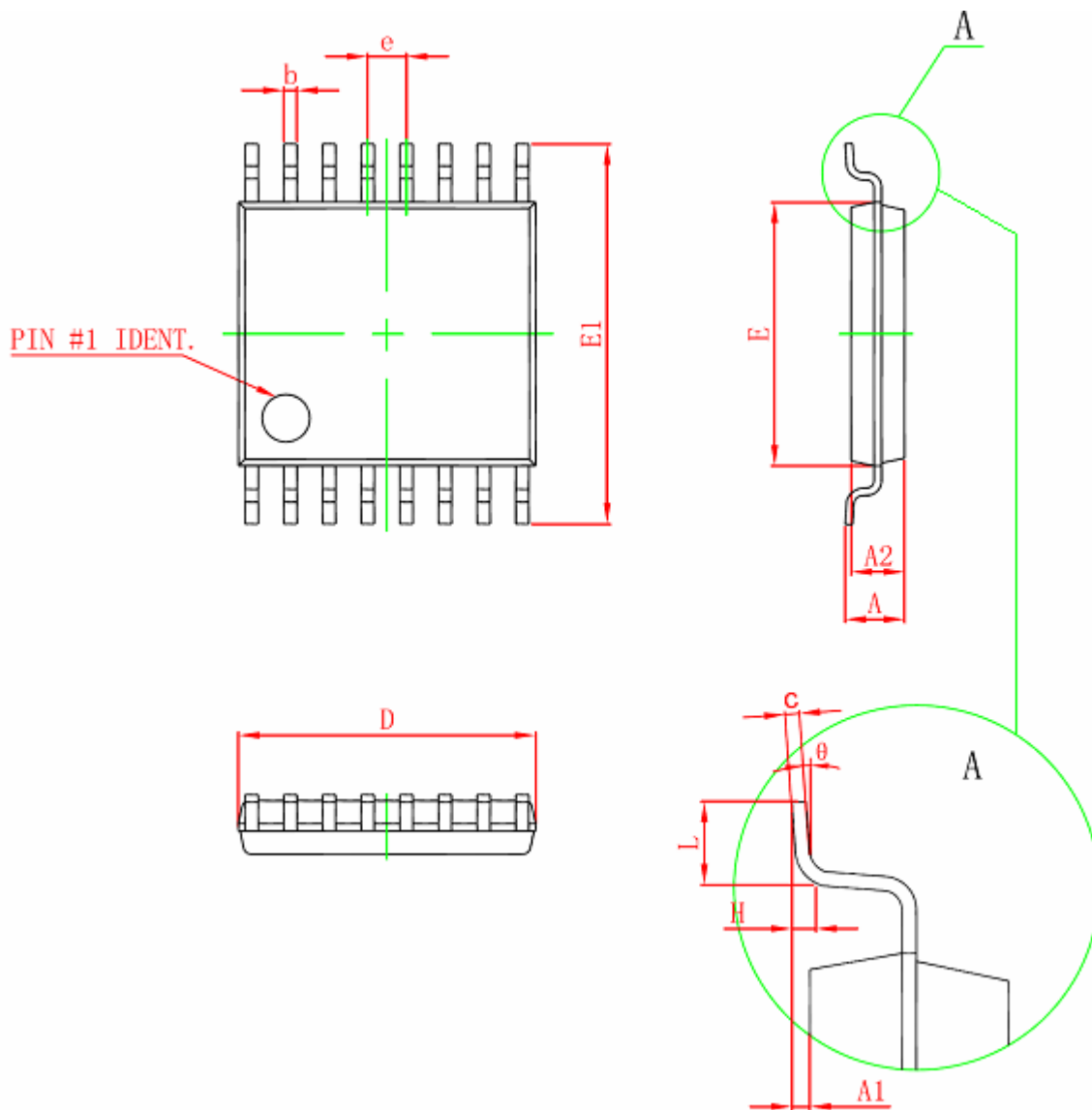

Figure 4 Kelvin Sensing of Charge Current

CONSONANCE

Package Information



Symbol	Dimensions In Millimeters		Dimensions In Inches	
	Min	Max	Min	Max
D	4.900	5.100	0.193	0.201
E	4.300	4.500	0.169	0.177
b	0.190	0.300	0.007	0.012
c	0.090	0.200	0.004	0.008
E1	6.250	6.550	0.246	0.258
A		1.100		0.043
A2	0.800	1.000	0.031	0.039
A1	0.020	0.150	0.001	0.006
e	0.65 (BSC)		0.026 (BSC)	
L	0.500	0.700	0.020	0.028
H	0.25 (TYP)		0.01 (TYP)	
θ	1°	7°	1°	7°

Consonance does not assume any responsibility for use of any circuitry described. Consonance reserves the right to change the circuitry and specifications without notice at any time.